

**Air Quality Monitoring Network
Standard Operating Procedures for the
BAM 1020 PM_{2.5} Monitors
Confederated Tribes of the Colville Reservation**

Prepared by

**Air Quality Program Manager
January, 2012**

Author 2-6-12
Date

APPROVED

Office of Environmental Trust Director 2-7-12
Date

Quality Assurance Manager 2/15/12
Date

Table of Contents

List of Figures	v
List of Tables	v
List of Abbreviation and Acronyms	vi
Introduction.....	1
Scope and Applicability	1
Definitions.....	3
Health and Safety Warnings	4
Personnel Qualifications	5
Installation Procedures.....	6
Unpacking, Inspection and Moving.....	6
Acceptance Testing.....	6
Power On and Warm Up; Page 15	7
72 Hour Field BKGD Zero Test; Page 19	7
¹ Pages shown are for operation manual revision G; pages for revision H are different but the sections are the same.....	7
Site Selection	8
Enclosure Selection.....	9
BAM Installation	9
Tools Needed for Installation.....	11
Install BAM 1020 in Enclosure	12
Insert Inlet Pipe and Install Smart Heater	12
Install Ambient Temperature and Barometric Pressure Sensors	12
Install the PM 2.5 and PM 10 Inlet Separator Heads.....	13
Wiring and Plumbing.....	13
Power to the Monitoring Sites	13
Power Connection to the BAM 1020 and Pump.....	13
Auxiliary Ground	13
Connect the Pump Tubing and Control Signal Cables	13
Pump Muffler.....	13
Connect the Air Temperature and Barometric Pressure Sensor	14
Connect the Smart Heater	14
Install Enclosure Temperature Sensor	14

CTCR Air Quality Monitoring Network SOP
February 2012

Connect to a Data Logger	14
Initial Setup and Configuration Check	15
Power On and Warm Up.....	15
Keypad Functions and Screen Displays.....	15
Loading Filter Tape.....	16
Perform a Self-Test	17
Set the BAM Clock.....	18
System Configuration Parameters.....	18
Conduct a Self-Test, Initial Leak Check and Flow Calibration.....	19
72 Hour Field BKGD Zero Test	19
Maintenance and Quality Control Procedures	21
Monthly Maintenance and QC.....	22
Flow Verification	22
Leak Check	23
Clean the Nozzle and Vane.....	23
Clean the Capstan Shaft and Pinch Roller Tires.....	24
Clean the PM ₁₀ Inlet.....	24
Clean the Collector Assembly	25
Clean the Acceleration Assembly	25
Clean the SCC™ and the VSCC™	26
Check Error Log	26
Digital Data Download	27
Two Month Maintenance and QC.....	27
Replace Filter Tape	27
Conduct Self-test.....	27
Flow, Temperature and Pressure Calibration.....	27
Verify the BAM 1020 Settings	29
Six Month Maintenance and QC.....	30
Service Pump Muffler.....	30
Test the Filter Temperature and RH sensors.....	30
Test Smart Heater	31
Twelve Month Maintenance and QC.....	31
72 hour Background Test.....	31
Clean or Replace internal debris Filter	31

CTCR Air Quality Monitoring Network SOP
February 2012

Check the Membrane Span Foil.....	31
Perform Beta Detector Count Rate and Dark Count Test.....	32
Clean Inlet Tube.....	32
Independent Audit.....	33
Replace Lithium Coin Cell Battery.....	33
Twenty Four Month Maintenance	33
Rebuild Vacuum Pump.....	33
Replace Nozzle O-rings	33
Replace Pump Tubing.....	33
Data Acquisition System.....	34
Data Validation and Quality Assurance.....	34
Quality Control Best Practices.....	34
Data Validation	34
Data Validation Steps	36
Diagnostics and Troubleshooting	37
Consumables and Spare Parts	37
References.....	38
Appendices.....	39

List of Figures

Figure 1: BAM 1020 Enclosure, Met One BX 903	9
Figure 2: Typical BAM 1020 Installation in an Enclosure, From Met One Operation Manual Revision G	10
Figure 3: BAM 1020 Keypad Grouping and Main Menu Screen Display	16
Figure 4: Filter Tape Routing in the BAM 1020	17
Figure 5: The self-test status screen following a test with no errors.	18
Figure 6: A cotton-tipped applicator and isopropyl alcohol are used to clean the BAM-1020 nozzle and vane.....	24
Figure 7: The PM10 inlet has two primary components, the Acceleration Assembly and the Collector Assembly.....	25
Figure 8: SCC™ and VSCC™ Particle Separator Components.....	26
Figure 9: MULTIPOINT FLOW CALIBRATION Screen.....	28

List of Tables

Table 1: Comparison of Two BAM 2010 PM _{2.5} Monitors	1
Table 2: Evaluation of the Nespelem BAM 2010 for FEM Configuration (updated July 2011) ...	3
Table 3: Acceptance testing procedures for the BAM 1020.....	7
Table 4: Site Selection Specifications for the BAM 1020.....	8
Table 5: Tools and Supplies for installing and operation of monitoring sites	11
Table 6: Wiring Connections Between the BX-596 AT and BP Sensor and the BAM 1020 Terminal Strip.....	14
Table 7: Wiring Connections Between the BX-592 AT Sensor and the BAM 1020 Terminal Strip	14
Table 8: Sample Screen Setting for the Nespelem and Inchelium BAM 1020	18
Table 9: Calibrate Screen Settings for the Nespelem and Inchelium BAM 1020	19
Table 10: Smart Heater Settings for the Nespelem and Inchelium BAM 1020.....	19
Table 11: Met One Recommended Maintenance Items and Schedule, BAM 1020	21
Table 12: Quality Control Action and Critical Criteria BAM 1020	22
Table 13: Verify BAM 1020 Settings.....	29
Table 14: Critical and operational data validation criteria for the Met One BAM.....	34
Table 15: Data Validation Steps for BAM 1020	36
Table 16: Suggested Consumable and Spare Parts to Keep Available.....	37

List of Abbreviation and Acronyms

¹⁴ C	Carbon 14
AT	Ambient Temperature
AQP	Air Quality Program
BAM	Beta Attenuation Monitor
BKGD	Background
BP	Barometric Pressure
CFR	Code of Federal Regulations
CTCR	Confederated Tribes of the Colville Reservation
DAS	Data Acquisition System
EPA	Environmental Protection Agency
FEM	Federal Equivalent Method
lpm	Liters per Minute
NAAQS	National Ambient Air Quality Standards
PM	Particulate Matter
SCC™	Sharp Cut Cyclone
SOP	Standard Operating Procedure
QA	Quality Assurance
QC	Quality Control
VSCC™	Very Sharp Cut Cyclone

Introduction

This document provides the standard operation procedures (SOP) for two monitoring sites within the exterior boundaries of the Colville Reservation. Both sites have a Beta Attenuation Monitor (BAM) model 1020 configured to measure particulate matter 2.5 microns (PM_{2.5}) or smaller, manufactured by Met One Instruments Inc. and installed with associated meteorological equipment.

Both monitors operated as non-regulatory for comparison to the National Ambient Air Quality Standards (NAAQS). Although the Inchelium monitor has the capability to function as a Federal Equivalent Method (FEM) monitor it will not be held to that standard. Every effort will be made to assure that data gained by both monitors are rigorously controlled by the procedures set in this SOP. This document relied heavily on a sample SOP written by David L. Vaughn of Sonoma Technology, Inc. and the BAM 1020 Operation Manual version G. Full citations for both documents are listed in the reference section of this SOP.

Scope and Applicability

The BAM-1020 employs the principle of beta ray attenuation to measure particulate mass concentration in ambient air, and reports hourly mass concentrations in micrograms per cubic meter, $\mu\text{g}/\text{m}^3$. Particles are collected by pulling a measured volume of ambient air through glass fiber filter tape. A ¹⁴C element emits a constant source of high-energy electrons (beta particles) that pass through the clean filter tape before sample collection and again after the filter collects particulate matter. The beta particles are attenuated as they collide with particles on the filter, and are detected and counted by a sensitive scintillation detector. The attenuation through the clean filter is compared with that of the particle-laden filter. The decrease in signal detected by the BAM 1020 scintillation counter is inversely proportional to the mass loading on the filter tape, and, together with the known air volume, allows calculation of mass concentration.

This SOP applies to the monitoring network established within the exterior boundaries of the Colville Reservation. The network consists of two Met One BAM 1020 PM_{2.5} monitors located in Nespelem and Inchelium. The monitors were purchased at separate times (2005 and 2011) and with slightly dissimilar configurations. Table 1 lists all the features of each monitor for ease of comparison.

Table 1: Comparison of Two BAM 2010 PM_{2.5} Monitors

Feature	Nespelem BAM 1020	Inchelium BAM 1020
Year Purchased	2005	2011
Serial Number	E5889	M6457
Medo Pump 115 VAC	Yes	Yes
PM ₁₀ Sampling Inlet	Yes	Yes
PM _{2.5} Sharp Cut Cyclone Inlet Adapter	Yes	No
PM _{2.5} Very Sharp Cut Cyclone Inlet Adapter	No	Yes

CTCR Air Quality Monitoring Network SOP
February 2012

Moisture Controlled Inlet Heater	Yes	Yes
Mass Flow Control	Yes	Yes
Outside Temperature Sensor, Volumetric Flow	Yes	No
Sensor, Combined Humidity and Temperature	No	Yes
Outdoor Enclosure with Temperature Control	Yes	Yes
Volumetric Flow Calibration Kit	Yes	Yes

To meet the FEM requirements for measurement of PM_{2.5} mass as described in the Federal Register (73 FR 22362), the BAM 1020 must be

- Operated for 24 1-hr average measurements;
- Equipped with firmware revision 3.2.4 or later;
- Operated with or without an inlet tube extension (BX-823);
- Operated with or without external enclosures BX-902 or BX-903;
- Operated in accordance with the BAM 1020 Particulate Monitor Operation Manual, revision F or later, and the Very Sharp Cut Cyclone (VSCC™) supplemental manual;
- Equipped with a BX-596 ambient temperature and barometric pressure combination sensor;
- Equipped with an internal BX-961 automatic flow controller operated in actual (volumetric) flow control mode;
- Equipped with a standard BX-802 EPA PM₁₀ inlet head and a BGI VSCC™ (VSCC-A);
- Equipped with a BX-827 (110V) or BX-830 (230V) Smart Inlet Heater with the heater RH regulation set point at 35% and the temperature control set to “off”;
- Equipped with the 8470-1 revision D or later tape control transport assembly with close geometry beta source configuration;
- Used with standard glass fiber filter tape;
- Configured for a COUNT TIME parameter of 8 minutes and a SAMPLE TIME parameter of 42 minutes; and
- Supplied with a BX-302 zero filter calibration kit. (This kit must be used to audit the BKGD (background) value upon unit deployment and periodically thereafter, as described in the BX-302 manual.)

An evaluation of the BAM installed at the Nespelem site for potential upgrades that would meet the above standards was made by consulting the manufacturer and EPA (Table 2). The evaluation concluded that the older BAM could not be upgraded to meet the stringent FEM standards but it would still meet the monitoring goals for the program and preform as a non-regulatory monitor. A firmware upgrade to 3.2.4 was performed at the manufactures Grants Pass Oregon facility that brought the monitor closer to the FEM standards in the spring of 2010.

Table 2: Evaluation of the Nespelem BAM 2010 for FEM Configuration (updated July 2011)

Met One BAM 1020 Monitor - PM _{2.5} FEM Configuration			
Parameter	FEM configuration	Monitor configuration	FEM Criteria met
Particle separator	BGI VSCC-A	Sharp	No
Averaging time	1 hour	1 hour	Yes
Firmware	3.2.4 or later	3.6.2 updated	No
Operating Manual	Revision F or later	Revision F	Yes
VSCC Manual	Supplemental	Do not have	No
Temp/BP sensor	Met One BX-596	BX – 592 Temp only	No
Flow controller	Met One BX-961	Met One BX-961	Yes
Flow controller setting	Actual (volumetric) mode	Actual	Yes
PM ₁₀ inlet head	Met One BX-802	BX - 802	Yes
Inlet heater	Met One BX-827 or BX-830	BX - 827	Yes
Heater RH setting	35%	35%	Yes
Temp control setting	Off	Off	Yes
Tape control transport assembly	Met One 8470-1 revision D or later	No	No
Beta Source configuration	Close geometry	No	No
Filter tape	Standard glass fiber	Standard glass fiber	Yes
COUNT TIME	8 minutes	4 minutes	No
SAMPLE TIME	42 minutes	50 minutes	No
Zero filter calibration kit	Met One BX-302	No	No

Definitions

Audit: Refers to the group of procedures that, taken together and conducted during a single site visit, verifies the status of all aspects of the BAM 1020. These procedures include flow audits, mechanical audits, and auditing of the setup and calibration values.

Verification: Refers to the review of interim work steps to ensure they are acceptable, and to determine whether the system is consistent, adheres to standards, uses reliable techniques, and performs the selected functions in the correct manner. Steps are performed during the process of data collection and include such items as checklists and comparisons to standards.

Validation: Involves determining whether the system complies with the requirements and performs functions for which it is intended and meets the organization’s goals and user needs. It is a determination of correctness of the data, and is usually performed periodically.

Quality Control: Refers to the operational techniques and activities used to fulfill the requirements for quality. This includes conducting maintenance and verification procedures in the field on the BAM 1020.

Quality Assurance: Refers to the planned or systematic activities used to provide confidence that the requirements for quality are fulfilled. Independent audits are a quality assurance activity.

Calibration: Refers to the act of adjusting an instrument after comparison with a standard.

Calibration Check: Refers only to checking an instrument against a standard and involves no adjustment of the instrument.

Health and Safety Warnings

Safety precautions should be heeded during the setup and operation of the BAM 1020. Standard safety rules regarding electricity and power tools should be observed at all time. The BAM 1020 contains a radioactive component which is explained by this direct quote from the Met One BAM Operations Manual (Rev G).

“The Met One Instruments BAM-1020 contains a small ¹⁴C (Carbon 14) beta radiation-emitting source. The activity of the source is **60 μCi ±15μCi** (microcurie), which is below the “Exempt Concentration Limit” as defined in 10 CFR Section 30.70–Schedule A. The owner of a BAM-1020 is not required to obtain any license in the United States to own or operate the unit. The owner of a BAM-1020 may elect to return the entire unit to Met One Instruments for recycling of the ¹⁴C source when the unit has reached the end of its service life, although the owner is under no obligation to do so. Under no circumstances should anyone but factory technicians attempt to remove or access the beta source. The beta source has a half-life of about 5730 years, and should never need to be replaced. Neither the ¹⁴C source nor the beta particle detectors are serviceable in the field. Should these components require repair or replacement; the BAM-1020 must be returned to the factory for service and recalibration.”

Installation of the 10 meter meteorological tower requires several precautions. Follow manufactures installation procedures for initial setup and reverse these if dissembling occurs. The tower should be placed 2 times the height at a minimum away from hazards such as electric lines. Plan the process before beginning and coordinate with all involved. Do not use metal ladders, work on wet or windy days but wear rubber soled shoes and other personal protective equipment. The complete manufactures safety and installation instructions are on file in the Air quality Program office.

The monitor enclosure and chassis ground on the BAM 1020 should be connected with a suitable ground point such as a rod.

Personnel Qualifications

The quality assurance (QA) procedures detailed in this SOP require an understanding of the BAM 1020 flow system, calibration protocol and normal operating processes. EPA *Guidance for Quality Assurance Project Plans* (U.S. Environmental Protection Agency, 2002) recommends that all field operations personnel should be familiar with environmental field measurement techniques including:

- Operation of the PM_{2.5} sampler;
- Calibrate, audit, and troubleshoot the PM_{2.5} sampler; and
- Use common methods to determine temperature, pressure, and flow rate.

Several training opportunities exist for the operation of the BAM 1020 that new and current personnel could benefit from. Met One offers a free in house class at their Grants Pass facility that covers installation, operation, maintenance and troubleshooting. The Institute for Tribal Environmental Professionals (ITEP) offers a similar three day class sporadically depending on requests.

Installation Procedures

The tasks associated with installation include unpacking and inspection of the BAM 1020 components, acceptance testing, site selection to meet 40 CFR Part 58 siting requirements, enclosure selection, installing the BAM 1020 main unit and supporting peripheral hardware, and instrument configuration procedures. Many of the items in the previous list also apply to moving and setting up of the BAM 1020 purchased in 2005.

Unpacking, Inspection and Moving

A physical inspection of the BAM 1020 system should be made upon receipt from Met One. Visible damage to the shipping container needs to be reported to the carrier and a claim filed immediately. Notify Met One after informing the commercial carrier of any problems. System components should be verified against the packing list and any missing or damaged components reported immediately to Met One. The BAM 1020 is shipped with two white foam rings and a white plastic shim inside the front of the unit, which prevent the moving parts of the tape control assembly from being damaged in transit. Do not remove the foam rings until the BAM 1020 is ready to be installed. These rings must be in place on the transport assembly anytime the unit is being moved in order to avoid damaging the tape control mechanism. The special box and foam packing material that the BAM 1020 is shipped in should be stored, in the event the unit must be returned to the factory.

Acceptance Testing

After the components have been verified against the packing list, the system should be assembled on a bench and an acceptance test performed. Utilize the instructions and tools in the BAM 1020 service tool kit (BX-308) to confirm all components in the BAM 1020 are correctly aligned and functioning properly. A copy of the instruction for the tool kit can be found in Appendix H. Components checked will be: Tape Reel Adjustment; Dark Count Test and Nozzle Spacing. Follow the instruction under BAM Installation for installing individual components for the bench test.

A zero test will be part of the bench test procedure to verify that the unit is working properly before being transported to the monitoring site. A 72-hr zero filter, or background, at the time of field installation will also be conducted to meet the requirements of FEM EQPM-0308-170. It is important that this test take place at the field site to account for site-specific background noise.

A list of suggested acceptance testing protocols for the BAM 1020 with a reference to the applicable sections of the SOP and the Operation Manual (Rev G.) are shown in Table 3. Acceptance testing should be performed on any monitoring equipment that are relocated and/or stored for extended periods.

Table 3: Acceptance testing procedures for the BAM 1020

Test	Location	Comments	SOP Section	BAM 1020 Operation Manual Section¹
Power on and Warm up	Bench	Verify that the BX-596 temperature and pressure readings are realistic and auxiliary sensor signals are functioning	Power On and Warm Up; Page 15	Power On; 3.1 Page 19
Verify Settings	Bench	Confirm all settings are correct	Verify BAM 1020 Setting; Page 29	Setup Menu; 6 Page 39
Self-test	Bench	Load tape and run self-test	Perform Self-Test; Page 17	Self-Test; 3.5 Page 22
Flow Verification/Calibration	Bench	Follow instruction below	Flow, Temperature and Pressure Calibration Page 28	Field Calibration of Flow System – Actual; 5.6 Page 35
Leak check	Bench	Should be < 1.0 lpm	Leak Check; Page 23	Leak Check Procedure; 5.3 Page 32
Filter-T and RH Test	Bench	+/- 1 deg C; RH reasonable	Test the Filter Temperature and RH sensors Page 30	Filter-T Test; 7.18 Page 62
Service Tool Kit	Bench	Follow instructions for BX-308 tool kit	Appendix H	Instructions with tool kit
Zero test	Bench and Field	Follow instruction with BX-302 zero filter calibration kit	72 Hour Field BKGD Zero Test; Page 19	Zero Background Tests; 7.7 Page 57

¹Pages shown are for operation manual revision G; pages for revision H are different but the sections are the same.

Site Selection

Site selection ensures uniform collection of compatible and comparable data by meeting standard criteria. The criteria shown in Table 4 are based on 40 CFR Part 58, App E applicable to ambient monitoring of PM_{2.5} and 40 CFR Part 58, App D, and Section 4.7 general monitoring requirements. Additional information can be found in the BAM 1020 operation manual, section 2.3.

Table 4: Site Selection Specifications for the BAM 1020

Siting Parameter	Situation	Specification	Comments
Inlet Height	General	2 m to 15 m above ground level	These heights are considered in the breathing zone
	Co-located samplers	All inlets optimally at same height	Sample inlets must be within 1 vertical meter of each other
	Inlet tube length	Maximum 16 ft.	Needs to be accessible for flow verifications and leak checks
Inlet radius clearance	General	Minimum 1 m radius clearance	Includes other sampler inlets or objects that may influence airflow
	Co-located samplers	From 1 m to 4 m between inlets	2 m recommended
	Near small obstructions	Minimum 2 m	Fences, walls
	Near large obstructions	Distance of 2X height of obstruction	Buildings or natural features
	Overhanging trees	Minimum 20 m from tree drip line	
	Arc of unrestricted air flow	Unrestricted 270 degree arc	Prevailing direction of concentration must be in the arc
Nearby particulate sources	General	As far away as possible from blowers or vents	Should not be influenced by wood heating sources
Distance from roadways	Less than 3,000 Vehicles per day	Minimum 5 m from nearest traffic lane	
	Unpaved roads	As far away as possible	
	Other unpaved areas	As far away as possible	Unpaved sites with vegetative ground cover are acceptable

Enclosure Selection

Both monitors and associated components will be housed in an environmentally controlled enclosure purchased from Met One (BX 903, Figure 1). These are a small self-contained enclosure with internal factory set environmental controls to maintain a constant temperature inside. These enclosures are specifically designed for the BAM 1020 and come with rack mounts; two access doors; weather proof seal on top; 120 volt power cord and cabinet mounting holes. Complete specifications, operation and maintenance instruction can be found in the BX-903 operations manual in Appendix A.

Figure 1: BAM 1020 Enclosure, Met One BX 903



BAM Installation

The Met One BAM-1020 Operation Manual (Rev G, Chapter 2) covers all aspects of BAM installation procedures. This SOP refines these to be specific to the monitoring network on the Colville Reservation. Figure 2 shows a typical BAM 1020 installation and includes all the peripheral components such as the smart heater and air pump. The enclosure depicted is the smaller BX 902 without climate controls.

Figure 2: Typical BAM 1020 Installation in an Enclosure, From Met One Operation Manual Revision G

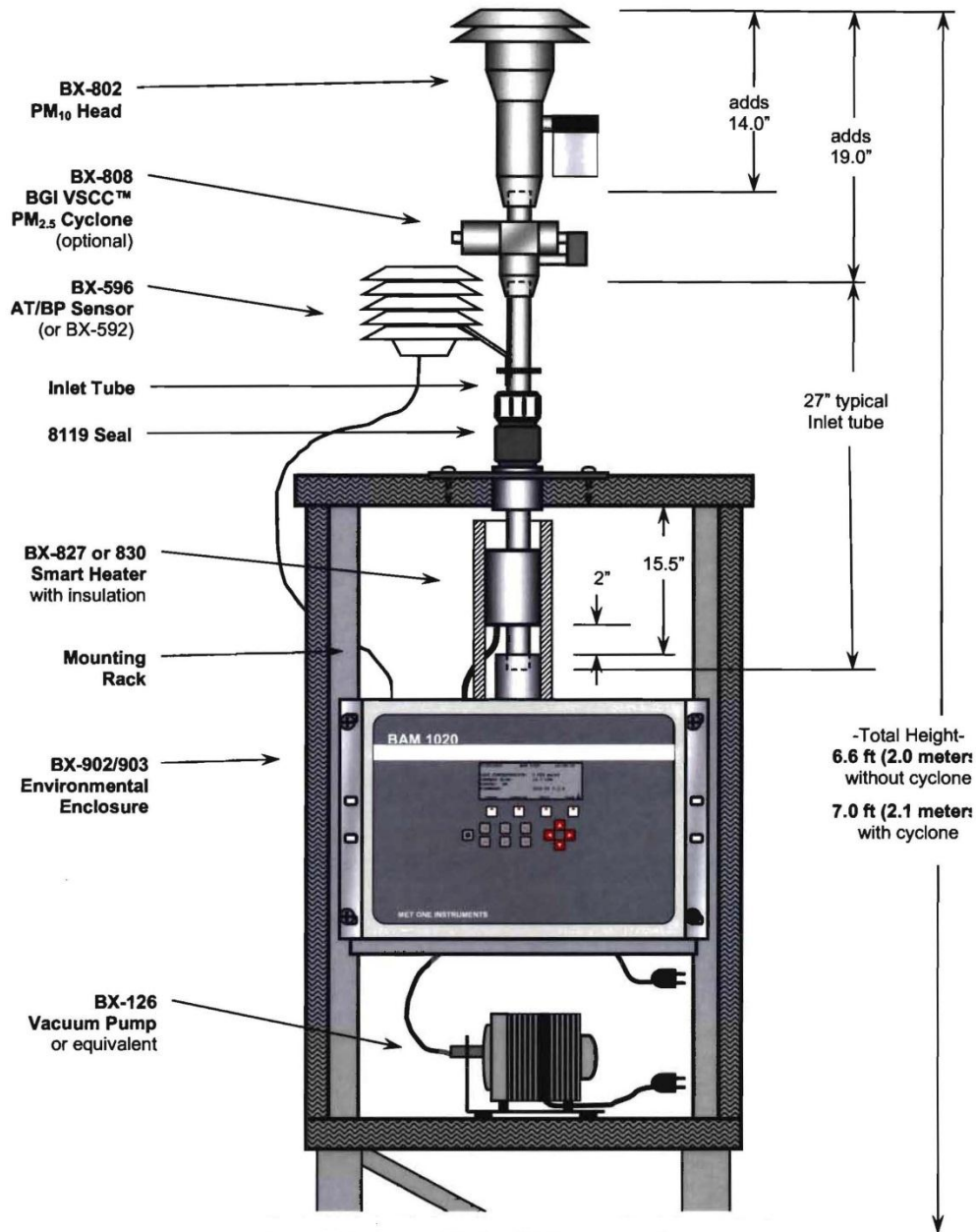

Tools Needed for Installation

Possessing the correct tools to install and perform necessary maintenance and repairs are essential for the smooth operation of the monitoring system. Table 5 provides a list of common tools and supplies for the monitoring network.

Table 5: Tools and Supplies for installing and operation of monitoring sites

Tools and Supplies	Comments
Drill with hole saw and bits	Half-inch, variable speed drill to create holes for cables through walls of cabinets
Tool Kit	Includes screwdriver, pliers, crescent wrench, allen wrench, nut drivers, tape measure, etc. Purchased in 2005, augmented in 2011
All weather caulking	Waterproof holes created for wiring
Hand cart	Moving enclosure
Masking tape	Installing filter tape on take up spool
Cotton tipped applicators	Nozzle cleaning
BAM 1020 service tool kit	BX-308 includes nozzle shims, spring scales, reel spacer, filter sensor removal tool and detailed instructions
Flow inlet adapter kit	BX-305 Perform leak checks
Zero filter calibration kit	BX-302 with 0.2 micron filter, perform zero checks
Volumetric Flow Calibration Kit	BX-307 BGI deltaCal, flow, temperature and pressure reference standard
Pump rebuild kit Medo	Rebuild pump if needed or every 2 years
Muffler replacement	Mufflers clog with small particles and affect air flow
Filter Element Pisco in-line	Replace filter as needed
Clear Tubing	Replacement tubing between pump and BAM 1020
O-ring kit	Common O-rings needed on the BAM 1020
BAM inlet cleaning kit	Includes pull-rope, tub brush, microfiber rags, cleaning brushes, O-ring grease and cotton applicators

Install BAM 1020 in Enclosure

The BX 903 enclosure is specifically designed for the BAM 1020 and includes the top sample pipe flange, shelf and rack mounts for the precise placement of the instrument. Place the BAM 1020 on the shelf and fasten to the rack brackets with the screws provided. This configuration provides the steadiest position and the most access room. With this configuration the inlet pipe should align properly with the inlet receiver on the BAM 1020. The enclosure should be positioned so that during operations and maintenance the door will provide a shield from the prevailing wind. This is particularly important during precipitation events to minimize moisture entering the enclosure.

Insert Inlet Pipe and Install Smart Heater

Remove the white cap and rubber seal from the flange assembly and set aside. Lower the inlet tube through the flange assembly in the roof and into the inlet receiver on the BAM 1020. Make sure the inlet tube is fully seated. Check that the inlet tube rotates freely. If it does not, there may be an inlet alignment problem that needs to be corrected before proceeding.

Temporarily lift the inlet tube out of the BAM 1020 and slide the Smart Heater onto the inlet tube, with the heater cable positioned toward the bottom. Reinsert the inlet tube into the BAM 1020 and check that it is fully seated. Position the Smart Heater 2 inches above the BAM 1020 inlet receiver and tighten the two set screws that attach the heater to the inlet tube. Wrap the supplied 12 inch cylindrical insulation around the heater body, and peel back the adhesive cover strip to secure it in place or tape closed.

Wet the inlet pipe rubber seal with water or alcohol and slide it down the pipe until it sits inside the gray plastic fitting that was previously screwed into the roof flange. This grommet is tight fitting, and wetting it will help slide it along the pipe. Be careful not to apply too much water or alcohol to avoid trickling down the tube into the inlet receiver on the top of the BAM-1020. When the grommet is in place, slide the white cap down the inlet and hand tighten it to the gray plastic fitting.

To prevent the buildup of a static charge on the inlet tube a solid station ground must be established with the BAM 1010 chassis. Tightening the two ¼-20 set screws located in the inlet receiver of the BAM creates a ground connection between the tube and the chassis, this action also secures the tube in place. To check if a competent ground has been established scrape a small spot on the clear anodizing near the bottom of the inlet tube and measure the resistance between the spot and the chassis ground terminal on the back of the BAM 1020. The resistance should be a few ohms or less.

Install Ambient Temperature and Barometric Pressure Sensors

The BX-596 Ambient Temperature (AT) and Barometric Pressure sensor (BP) combination sensor attaches directly to the inlet tube with a supplied U-bolt. The combination BX-596 is installed at the Incheilium site. The BX-592 ambient temperature sensor is attached to the inlet tube using the cross arm assembly at the Nespelem site. Input from these sensors provides correction values as part of the volumetric flow calculations.

Install the PM 2.5 and PM 10 Inlet Separator Heads

A BGI Sharp Cut Cyclone will be installed on top of the inlet tube beneath the standard PM 10 inlet head on the Nespelem monitor. The Inchelium monitor will have a BGI Very Sharp Cut Cyclone (VSCC) installed on the inlet tube under the PM 10 inlet head. See Appendix K for VSCC instruction and maintenance information.

Wiring and Plumbing

Wiring connections include power availability to the outdoor enclosure, chassis ground wire, power distribution within the cabinet, use of an uninterruptable power supply (UPS), smart heater installation, and connection of the BAM 1020 and air pump.

Power to the Monitoring Sites

The Nespelem and Inchelium sites will have electricity provided from a metered connection to an outdoor quality breaker box and outlet. The enclosure will be plugged into the three prong outlet to run the heater/air conditioner, and the monitoring equipment. The site plans provided in Appendix B details the location of the meter, underground wires, breaker box, outlet and enclosure.

Power Connection to the BAM 1020 and Pump

A power strip wired into the enclosure junction box on the inside of the cabinet provides electric availability to all equipment installed. The power strip includes an on/off switch that controls the components plugged into it. An uninterruptable power source (UPS) with voltage modulation plugs into the strip and then provides power to the BAM 1020 and air pump. See the Compu-cessory model 25650 user manual in Appendix J for basic operation and troubleshooting options

Auxiliary Ground

A ground connection between the chassis ground terminal on the rear terminal strip of the BAM 1020 and the grounding rod will be established by utilizing the green/yellow wire provided with each monitor. Additionally the enclosure will be grounded to the same rod.

Connect the Pump Tubing and Control Signal Cables

The Medo pumps will be placed under the shelf on the floor of the cabinet. The air tubing (clear 10mm O.D., 6.5mm I.D. Polyurethane) connects to the BAM with a compression fitting and then to the air pump. Connect the two-wire signal cable supplied with the pump to the terminals on the back of the BAM marked "Pump Control". The polarity of the wires does not matter, but the end of the cable with the square black ferrite filter goes toward the BAM 1020. Connect the other end of the cable to the two terminals of the pump control box mounted on the pump.

Pump Muffler

The muffler on the Medo air pumps will eventually clog and cause a decrease of air flow through the system. This will cause a loss of data and eventually will harm the pump. The muffler should be replaced every 6 months or sooner if particulate matter concentrations are high. Alternately a length of tubing 3 foot long can be used to muffle the pump noise and be vented to the outside of the enclosure. A weather proof and bug resistant seal should be used if an outside vent is installed.

Connect the Air Temperature and Barometric Pressure Sensor

Connect the BX-596 AT and BP sensor to the rear terminal strip of the BAM 1020 as shown in Table 6 and 7 below.

Table 6: Wiring Connections Between the BX-596 AT and BP Sensor and the BAM 1020 Terminal Strip

BX-596 AT/BP Sensor	
Wire Color	Terminal Name
Yellow	Channel 6 SIG
Black/Shield	Channel 6 COM
Red	Channel 6 Power
Green	Channel 6 ID
White	Channel 7 SIG

Table 7: Wiring Connections Between the BX-592 AT Sensor and the BAM 1020 Terminal Strip

BX-592 AT Sensor	
Wire Color	Terminal Name
Yellow or White	Channel 6 SIG
Black/Shield	Channel 6 COM
Red	Channel 6 Power
Green	Channel 6 ID

Connect the Smart Heater

The smart heater connects to the back of the BAM 1020 using two configurations depending on which year the monitor was manufactured. For the Nespelem monitor simply plug the heater cable directly into the mating green metal connector on the back of the BAM 1020, power to the heater is supplied by this connection. The newer Inchelium monitor smart heater comes with a grey relay box that plugs into the mating control connector on the back of the BAM 1020. The heater cable connects to the green receptacle on the top of the relay module. A power cord from the relay box to the power strip provides electricity for operation.

Install Enclosure Temperature Sensor

The air temperature inside the enclosure must be held as constant as possible over the course of the hour. This is important because the unit measures the beta particles through a small gap of air around the filter tape at the beginning and the end of each hour. If the air temperature inside the enclosure has changed by more than about 2 degrees C during this time, the concentration measurement can be affected on the order of several micrograms. Temperatures must not exceed the range of 0 to 50 C° nor vary more than two degrees in an hour. A BX-592, a room temperature sensor wired to the back of the BAM 1020 is used to monitor enclosure temperature. The enclosures have preset temperature ranges that cannot be changed in the field. Large variation of enclosure temperature may indicate the AC/heater unit needs maintenance.

Connect to a Data Logger

A data acquisition system (DAS) will be installed at both sites in the future. As of the writing of this SOP data loggers and telemetry system had not been chosen. The DAS will connect to the BAM 1020 using the digital, RS 232 fitting or as an analog signal. A 2-conduction shielded

cable connects the terminals marked “VOLT OUT +, - on the back of the BAM to the DAS. When this step is implemented all manufactures recommendations of the DAS will be observed. Met One Instruments recommends connecting to a data logger with the RS232 whenever possible. A separate SOP will be written for this step in the future.

Initial Setup and Configuration Check

This section describes all the steps need to set up the BAM 1020 for proper functioning. Before deployment both monitors will be bench tested as described below.

Power On and Warm Up

The power switch on the power strip must be in the on position, the UPS on and the BAM plugged in. Press the switch on the back of the BAM to the on position and let warm up for 1 to 3 hours before data collection. If sensors are added when the BAM is not powered they may not be recognized by the monitor. To fix this problem simple cycle the power to the BAM and it will automatically recognize the sensors.

Keypad Functions and Screen Displays

The screen display and keypad work together to conduct routine operation, maintenance and troubleshooting of the BAM. The screen displays operator selectable choices that can be changed with the keypad directly below. The keypad is composed of four groups; soft key, contrast key, function keys and arrow keys as shown in Figure 3.

Soft Keys:

Directly beneath the display are four white buttons called “soft-keys”. The keys functions changes in response to a menu option displayed directly above on the bottom row of the display. These are used throughout the entire menu system for a wide variety of functions.

Arrow (Cursor) Keys:

The four red arrow keys are used to scroll up, down, left, and right to navigate in the menu system, and to select items or change fields on the screen. The arrow keys are also often used to change parameters or increment/decrement values in the menu system.

Contrast Key:

The key with a circular symbol on it is for adjusting the light/dark contrast on the LCD display. Press and hold the key until the desired contrast is achieved. It is possible to over adjust the contrast and make the entire display completely blank or completely dark, so be careful to set it to a visible level or it may appear that the unit is not operating. The older Nespelem monitor does not have this key.

Function Keys F1 to F6:

The function keys serve as shortcuts to commonly used menu screens, and can be safely pressed at almost any time without interrupting the sample cycle. The F keys are only functional from the main menu screen or for entering the password. The factory default password is F1, F2, F3, F4. Key F1 displays current (instantaneous) data; F2 displays latest average data; F3 displays errors, sorted by date; and F4 allows viewing of up to 12 days of stored concentration, flow volume, and external channel data. Key F5 is use to copy the memory contents to an optional transfer storage module without utilizing a computer and is rarely used and Key F6 is not assigned a data function.

Figure 3: BAM 1020 Keypad Grouping and Main Menu Screen Display

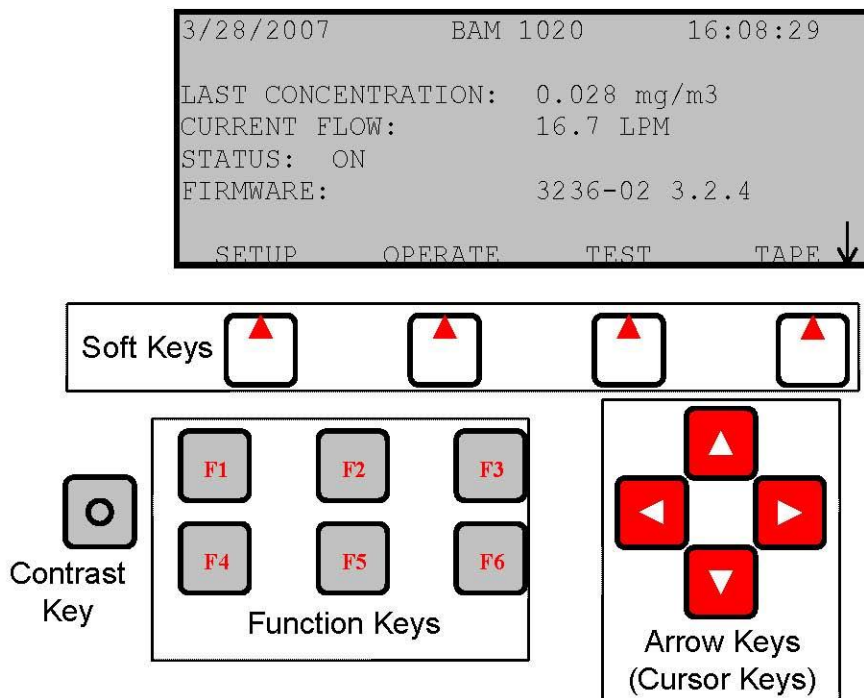

Loading Filter Tape

A roll of filter tape must be loaded into the BAM 1020 for sampling. Under normal operations a roll of filter tape will last 60 to 70 days. A supply of spare rolls will be kept on hand to assure the continuing operation of the monitors.

Met One recommends wearing lint-free cotton gloves when handling the tape but clean bare hands with minimal touching of the tape works. Only new un-used filter will be used.

Steps for loading a roll of filter tape:

1. Turn the BAM 1020 on and enter the TAPE menu (Note: This menu is not the same as the TEST > TAPE menu). If the nozzle is not in the UP position, press the TENSION soft-key to raise the nozzle.
2. Lift the rubber pinch roller assembly (Figure 4) and latch it in the UP position. Unscrew and remove the clear plastic spool covers on the supply and take up reels.
3. An empty core tube **MUST** be installed on the left (take-up) reel hub to provide a surface for the used tape to spool-up on. A plastic core tube for use with the first roll of tape is supplied. Then use the empty core tube left over from the last roll to spool-up the new roll. Never fasten the filter tape to the aluminum hub.
4. Load the new roll of filter tape onto the right (supply) reel, and route the tape through the transport assembly as shown in Figure 4. Attach the loose end of the filter tape to the empty core tube with cellophane or masking tape.
5. Rotate the tape roll by hand to remove excess slack; then install the clear plastic spool covers. The covers will clamp the rolls to the hubs to prevent slipping.

6. Align the filter tape so that it is centered on all of the rollers. The IncheIium unit has score marks on the rollers to aide with centering the tape, the Nespelem unit does not.
7. Unlatch and lower the pinch roller assembly onto the sample tape. The BAM will not function if the pinch rollers are latched up. An error message will be generated in the self-test if the pinch rollers are still latched.

Figure 4: Filter Tape Routing in the BAM 1020

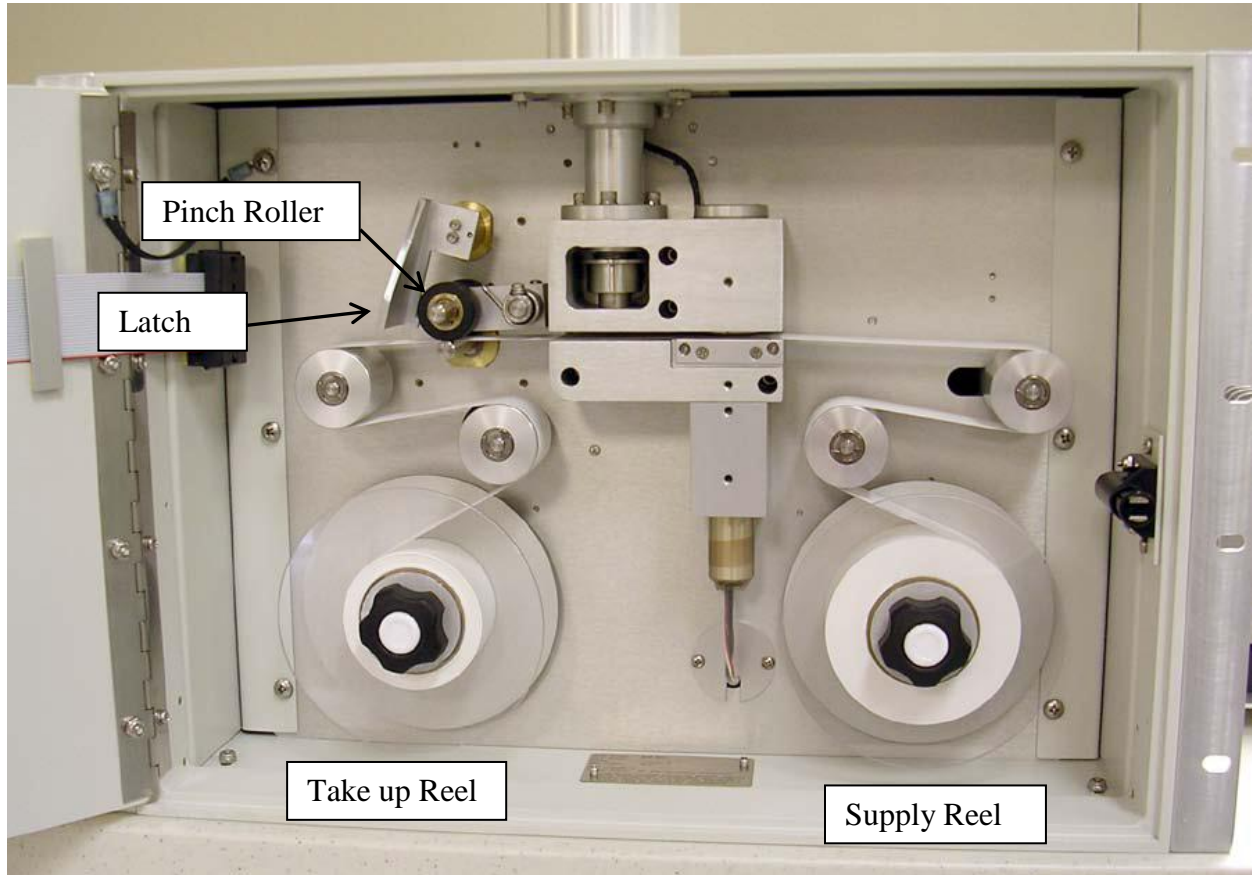

Perform a Self-Test

The self-test function should be run after each filter tape change or any time that troubleshooting is undertaken because it automatically tests most of the tape control and flow systems of the unit. Press the TAPE soft key and then press the SELF TEST soft-key to start the test. The test takes several minutes; the BAM-1020 displays the results of each tested item with an OK or a FAIL tag. If all the test items are OK, the self-test status screen will show “SELF TEST PASSED”, as shown in Figure 5. If any item fails, the self-test status screen will show “ERROR OCCURRED”. A description of all the parameters listed in the self-test screen is given in the BAM 1020 Operation Manual (Rev G, page 23). Press the soft key under exit to return to the tape screen.

Figure 5: The self-test status screen following a test with no errors.

```

02/08/1999      15:29:30
LATCH: OFF      TAPE BREAK: OK
CAPSTAN: OK     TAPE TENSION: OK
NOZZLE DN: OK   SHUTTLE: OK
NOZZLE UP: OK   REF EXTEND: OK
FLOW: OK        REF WITHDRAW: OK
Status:  SELF TEST PASSED
TENSION  SELF TEST          EXIT
    
```

Set the BAM Clock

Press the SETUP Soft Key on the main screen to access the clock setting. Use the Arrow Keys to move to the desired menu item and press the SELECT Soft Key to display the information. BAM 1020 time is a 24-hr clock only. Use the arrow keys to select and increase/decrease the desired field, then press the SAVE soft-key. The BAM1020 clock may drift as much as a minute or two per month and should be checked monthly to ensure correct sample timing. The BAM clock should be permanently set for Pacific Standard Time and should never be reset to Daylight Savings Time.

System Configuration Parameters

Three screens must be viewed to verify that the BAM 1020 is properly configured: the SAMPLE screen, the CALIBRATE screen, and the HEATER screen. Detailed descriptions of other SETUP menu screens are given in the BAM 1020 Operation Manual (Rev G, pages 39-51).

Table 8: Sample Screen Setting for the Nespelem and Inchelium BAM 1020

Sample Setup Setting	Nespelem Monitor	Inchelium Monitor
RS232	9600 baud	9600 baud
BAM Sample	50 minutes	42 minutes
Station Number	2	3
Met Sample	60 minutes	60 minutes
Range	1.00 mg	1.00 mg
Offset	-0.015	-0.015
Concentration Units	µmg/m ³	µmg/m ³
Count Time	4 minutes	8 minutes

Each BAM 1020 is calibrated at the factory and has unique settings that are provided on an accompanying calibration certificate. A copy of this certificate, specific to the instrument's serial number, will be kept at each site and on file in the air quality program office. The SETUP > CALIBRATE screen stores most of the factory-determined calibration parameters for the BAM 1020. These settings will never be changed without specific instructions from Met One under most circumstances. The setting will be periodically reviewed during verifications and audits.

Table 9: Calibrate Screen Settings for the Nespelem and Inchelium BAM 1020

Calibrate Setting	Nespelem Monitor	Inchelium Monitor
Flow Rate	16.7 lpm	16.7 lpm
Concentration Type	Actual	Actual
Flow Type	Actual	Actual
ABS	0.791	0.807
CV	0.990	1.022
Qo	0.00	-0.099
μsw	0.293	0.299
K	0.939	0.966
BKGD	-0.0036	-0.0023
Standard Temperature	25 C	25 C
Heater	Auto	Auto
Sensor		Unused
Query	NA	Unused
Reports	NA	01:00 to 24:00

The heater setup screen becomes available when the heater mode in the calibrate screen is set to auto. The Smart Heater will be automatically turned on to full power whenever the humidity of the sample stream exceeds the RH Setpoint.

Table 10: Smart Heater Settings for the Nespelem and Inchelium BAM 1020

Calibrate Setting	Nespelem Monitor	Inchelium Monitor
RH Control	Yes	Yes
RH Setpoint	35%	35%
Datalog RH	Yes (Channel 4)	Yes (Channel 4)
Delta-T Control	No	No
Delta-T Setpoint	99 C	99 C
Detalog Delta-T	No (Channel 5)	No (Channel 5)

Conduct a Self-Test, Initial Leak Check and Flow Calibration

Follow the instructions for a self-test as described above; Performing a Self-test. Then continue to the Maintenance and Operational Procedures for instruction on conducting a leak check and flow calibration.

Exit to the Main Menu screen and verify that the “Status” line displays “ON” and that there are no errors. The unit will start the sampling cycle at the beginning of the next hour. Let the BAM 1020 operate for several hours before proceeding to the zero (BKGD) test.

72 Hour Field BKGD Zero Test

The BKGD value is a correction offset for beta-source fluctuations, mechanically induced bias, and site-specific interferences such as radio frequency or other electromagnetic perturbations that can cause bias in concentration measurements (see BAM-1020 Operation Manual, Rev G, Sections 6.3 and 7.7). This value is factory-calibrated for each unit under laboratory conditions,

CTCR Air Quality Monitoring Network SOP
February 2012

but BAM 1020 units set up to monitor PM_{2.5} under FEM EQPM-0308-170 must have this value field verified (and adjusted if necessary) when deployed in its normal operating environment, and periodically afterwards, using the BX-302 Zero Filter Calibration Kit. Met One provides a separate manual which will be followed at both monitoring sites (Appendix E). The BAM 1020 does not provide a flag or otherwise mark the data recorded while conducting a zero test so write down the start and finish times of the test.

After the bench and initial field installation 72 hour zero tests the monitors will be checked periodically to verify the values are valid. This test will be conducted on an annual basis to mimic the FEM guidance.

Maintenance and Quality Control Procedures

This document provides an established regularly recurring protocol of maintenance and QC procedures to ensure that a continuous stream of high quality hourly PM_{2.5} concentration data is obtained. Table 11 lists the Met One recommended maintenance and QC procedures and frequencies of recurrence. While conducting maintenance, tolerance values as shown in Table 12 are essential to verify the smooth operation of the BAM 1020.

Table 11: Met One Recommended Maintenance Items and Schedule, BAM 1020

Maintenance Item	Suggested Period
Flow Verification	Monthly
Conduct Leak Check	Monthly
Clean the Nozzle and Vane	Monthly
Clean the Capstan Shaft and Pinch Roller Tires	Monthly
Clean the PM10 Inlet	Monthly
Clean the VSCC™	Monthly
Check the Error Log	Monthly
Download the Digital Data Log	Monthly
Compare BAM-1020 Data to External Data logger Data	Monthly
Replace Filter Tape	2 Months
Run SELF-TEST Function	2 Months
Verify Flow and Conduct Volumetric Flow Calibration P and T checks	2 Months
Verify BAM-1020 Settings and Check Real-Time Clock	2 Months
Replace or Clean Pump Muffler (if used)	6 months
Test Filter Temperature and RH sensors	6 months
Test Smart Heater	6 months
Perform 72 hour BKGD (BX-302 zero filter) test	12 months
Clean Internal Debris Filter	12 months
Check Membrane Span Foil	12 months
Perform Beta Detector Count Rate and Dark Count Test	12 months
Clean Inlet Tube	12 months
Test Analog DAC Output (if used)	12 months
Independent audit	12 months
Replace lithium coin cell battery on 3032 circuit board	12 months
Rebuild Vacuum Pump	24 months
Replace Nozzle O-ring (Special tools required)	24 months
Replace Pump Tubing	24 months
Factory Recalibration. Not required except for units sent for major repairs.	

Table 12: Quality Control Action and Critical Criteria BAM 1020

QC Check	Tolerance	Class	Procedure
Flow Rate 16.7 lpm	> ±4% (16.00-17.34)	Action	Trouble Shoot Leak and /or Recalibrate Instrument Flow Rate
Leak Check	>1.5 lpm		
Flow Rate 16.7 lpm	> ±6% (15.67-17.67)	Critical	Trouble Shoot Leak and /or Recalibrate Instrument Flow Rate and Invalidate Data Back to Last Good Audit
Leak Check	>3.0 lpm		
Temperature	± 2.5 °C	Action	Recalibrate Equipment
Pressure	± 6 mm Hg		
Temperature	± 4.0 °C	Critical	Recalibrate Equipment and Invalidate Data Back to Last Good Audit
Pressure	± 10 mm Hg		

Monthly Maintenance and QC

Monthly site visits with associated task are the minimal requirement to keep the BAM 1020 functioning and to guarantee high quality data. The form, BAM 1020 Verification Sheet, shown in Appendix C will be used for these visits. These forms provide spaces to document all of the recommended maintenance operations and quality control checks.

Order of events recommended for monthly QC:

1. Digital data download
2. Flow verification (as found)
3. Leak check (as found)
4. Nozzle and vane cleaning
5. Capstan shaft and pinch roller cleaning
6. PM10 inlet and Very Sharp Cut Cyclone cleaning
7. Leak check (as left)
8. Flow verification (as left)
9. Error log check

Flow Verification

Each monitor will be set to actual flow type. As shown in Table 12 the tolerance for the flow rate variation from 16.7 lpm is ±4% or 16.00 to 17.34 lpm. Flow verifications are conducted using a NIST-traceable flow reference standard. A deltaCal owned by the air program will be used and recertified by the manufacture each year. A copy of the deltaCal manual can be found in Appendix I. Start the process after the hour change when possible to allow the maximum time for the procedures. Record the flow verification measurement and other maintenance activates on the Verification Form shown in Appendix C.

The following steps enable “as found” flow rate verification:

1. Allow the flow reference standard to equilibrate with ambient conditions. This step can take up to 30 minutes, depending on where the flow standard was stored.

2. From the Main menu, press the TEST Soft Key, which will stop the sample cycle.
3. Select the TEST > FLOW menu to access the MULTIPOINT FLOW CALIBRATE screen; the password will be required.
4. Remove the sampling inlet head.
5. Press the NEXT Soft Key until "FLOW 3" is highlighted. The pump will be running and the flow controller will be regulating the flow to 16.7 lpm volumetric.
6. Attach the reference flow standard to the inlet tube and allow the reading to stabilize.
7. Record the "Actual Flow" volumetric flow rate from the flow reference standard.
8. Record the "BAM Indicated Flow" rate from the BAM column for FLOW 3.
9. If the "as found" flow reference standard reading is more than 4% different from 16.7 lpm (± 0.67 lpm, or outside the range 16.0 to 17.34 lpm), a flow calibration should be performed.
10. Record the actual flow and BAM indicated flow for the 15.0 and 18.3 lpm screens. These will be utilized when calculating QA values for bias and precision.
11. Continue with other maintenance and QC procedures and mark the results on the verification sheet. When complete, replace the sampling inlet head, and place the BAM into OPERATE mode.

Leak Check

The "as found" leak check should be performed after the "as found" flow verification. From the Main menu, press the TEST Soft Key and stop the sample cycle if running. Remove the sampler head from the inlet tube. Install a BX-305 or BX-302 leak test valve onto the inlet tube and turn the valve to the OFF position to prevent any air from entering.

In the TEST > TAPE menu, advance the tape to a fresh, unused spot. In the TEST > PUMP menu, turn on the pump. The flow rate should drop below 1.0 lpm. Write the flow rate under as found on the verification sheet. If the leak flow value is 1.0 lpm or greater, the nozzle and vane need cleaning, or there may be another small leak in the system. Resolve the leak and perform the check again. A properly functioning BAM with a clean nozzle and vane will usually have a leak value of about 0.5 lpm or less using this method. Turn the pump off, remove the leak test valve, and re-install the inlet heads.

As found leak checks show if a problem developed subsequent to the last maintenance check. Use the guidance shown in Table 12 to determine data viability. Generally leak checks should result in a flow of under 0.5 lpm if all is functioning well. With the buildup of debris around the nozzle/tape interface flows may increase up to 1 lpm, which indicates a cleaning is necessary. Values greater than 1 lpm may indicate additional air leak problems. In all cases of higher than expected leak values clean the nozzle and vane using the process described below.

Clean the Nozzle and Vane

The nozzle and vane (located under the nozzle) must be cleaned regularly to prevent leaks and measurement errors. The cleaning must be done at least each time the filter tape is changed, though monthly cleaning is highly recommended. Use the following steps to clean the parts. Refer to the photos below.

1. Raise the nozzle in the TEST > PUMP menu. Remove the filter tape (if installed) from the nozzle area. It is not necessary to completely remove the tape from the unit.

2. With the nozzle up, use a small flashlight to inspect the cross-hair vane.
3. Clean the vane with a cotton-tipped applicator and isopropyl alcohol (Figure 6). Hardened deposits may have to be carefully scraped off with the wooden end of the applicator or a dental pick or similar tool.
4. Lower the nozzle in the TEST > PUMP menu. Lift the nozzle with your finger and insert another cotton swab with alcohol between the nozzle and the vane. Let the nozzle press down onto the swab with its spring pressure.
5. Use your fingers to rotate the nozzle while keeping the swab in place. A few rotations should clean the nozzle lip.
6. Repeat the nozzle cleaning until the swabs come out clean.
7. Inspect the nozzle lip and vane for any burrs which may cause leaks or tape damage.

Figure 6: A cotton-tipped applicator and isopropyl alcohol are used to clean the BAM-1020 nozzle and vane

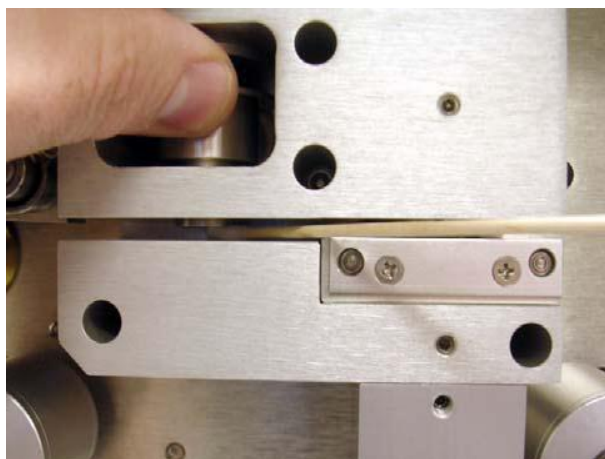

Clean the Capstan Shaft and Pinch Roller Tires

The capstan shaft is the stainless steel shaft that the rubber pinch roller rests on and can be seen in Figure 4. Use a cotton tipped swab moistened with isopropyl alcohol to wipe down the capstan shaft and pinch roller tires. This action is best completed when the pinch roller is latched in the UP position. Use the swab to clean the rubber pinch roller of any sample tape fragments adhering.

Clean the PM₁₀ Inlet

The PM₁₀ inlet needs to be disassembled and cleaned every 30 days. Met One currently recommends that the particle trap (or collector plate) located in the top part of the Collector Assembly (Figure 7) be cleaned monthly, and that the acceleration assembly be cleaned quarterly. A #2 Phillips screwdriver is needed to remove the top plates from the acceleration assembly of the PM₁₀ inlet. Hands should be clean for this procedure.

Figure 7: The PM10 inlet has two primary components, the Acceleration Assembly and the Collector Assembly.

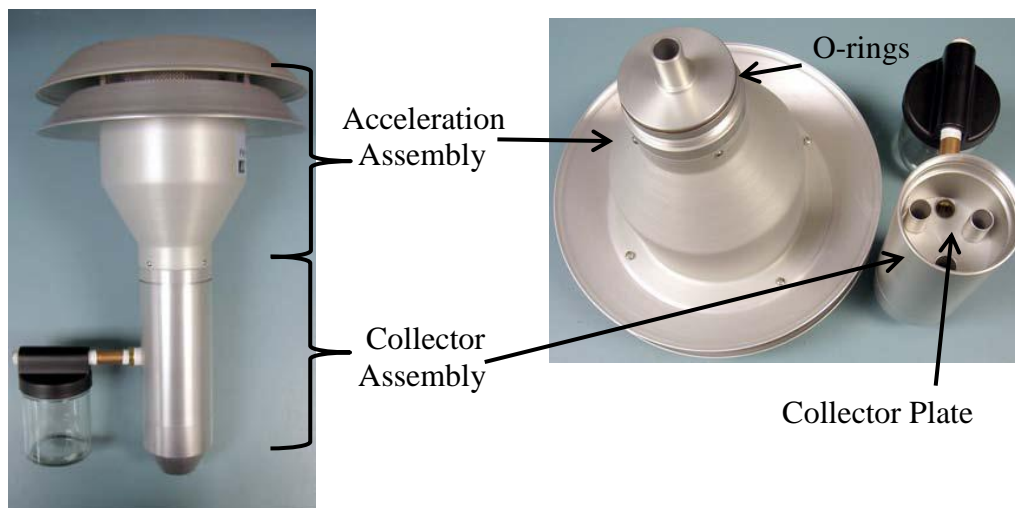

Clean the Collector Assembly

This task should be completed every 30 days

1. Remove the condensation jar and set it aside.
2. Unscrew the Collector Assembly (bottom portion of inlet) from Acceleration Assembly.
3. Use a brush, lint free cloth and/or cotton swabs to clean the bottom collector plate and the collector assembly walls around the three vent tubes, and the weep hole in the collector plate. Water can be used if needed. Allow to dry.
4. Clean inside the vent tubes by running a moistened cloth through them.
5. At the bottom of the Collector Assembly, wipe out the inside area where the two O-rings are situated.
6. Inspect the O-rings and replace if needed. Apply a thin film of O-ring grease on the O-rings.
7. Wipe out the condensation jar and the jar lid. Apply a thin film of grease to the cork seal inside the lid. Clean hands here too, before reassembling (e.g., using wet wipes).

Clean the Acceleration Assembly

This task should be completed quarterly

1. Set the Acceleration Assembly upside-down on its top plate and remove the four pan head screws on the bottom side. If the stand-offs turn, hold them in place with pliers.
2. Lift the Acceleration assembly off the top plate. Lift the lower plate up and carefully remove the insect screen.
3. Clean all the inlet parts of the Acceleration Assembly inside and out (top plates, insect screen, and the Accelerator Assembly body). Parts may only need to be wiped with brushes or a lint-free cloth, or blown out with compressed air. Alternatively the parts may actually be “washed” in clean water; this is the only good way to remove any caked deposits that may have accumulated in hard-to-reach places. Parts must be thoroughly dried before re-assembly. Pay special attention to the acceleration nozzle at the base of the cone-shaped body: clean the inside of the nozzle by pushing a moistened piece of

cloth through it. Inspect the large diameter O-ring at the base of the Accelerator Assembly.

4. Replace the O-ring if necessary, or apply a thin film of O-ring grease on the O-ring and a thin film on the aluminum threads of the acceleration assembly.
5. To avoid contamination of other items, clean hands with a wet wipe or similar material to clean off O-ring grease.
6. Reassemble the PM10 inlet.

Clean the SCC™ and the VSCC™

This task should be completed every 30 days. The Sharp Cut Cyclone (SCC) is installed on the Nespelem Monitor and the Very Sharp Cut Cyclone in on the Inchelium Monitor. See figure 8 for identification of parts mentioned below.

1. Remove the SCC™ or VSCC™ from its installed position in the instrument.
2. Pull off the side transfer tube. If it is too tight to remove by hand, pry it off with a rigid plastic lever. Care should be taken to not damage the two O-ring seals.
3. Unscrew the top cap and the grit pot.
4. Use alcohol wipes, or if unavailable, a dampened cloth, to remove all visible deposits. These deposits are most likely to be found at the bottom of the cone (located beneath the grit pot) and inside the grit pot.
5. Inspect all O-rings for shape and integrity. If at all suspect, replace. Lubricate all O-rings with light grease. It is important to well lubricate the transfer tube to avoid difficult disassembly.
6. Clean hands with alcohol wipe or similar media.
7. Assemble in reverse order and reinstall.

Figure 8: SCC™ and VSCC™ Particle Separator Components

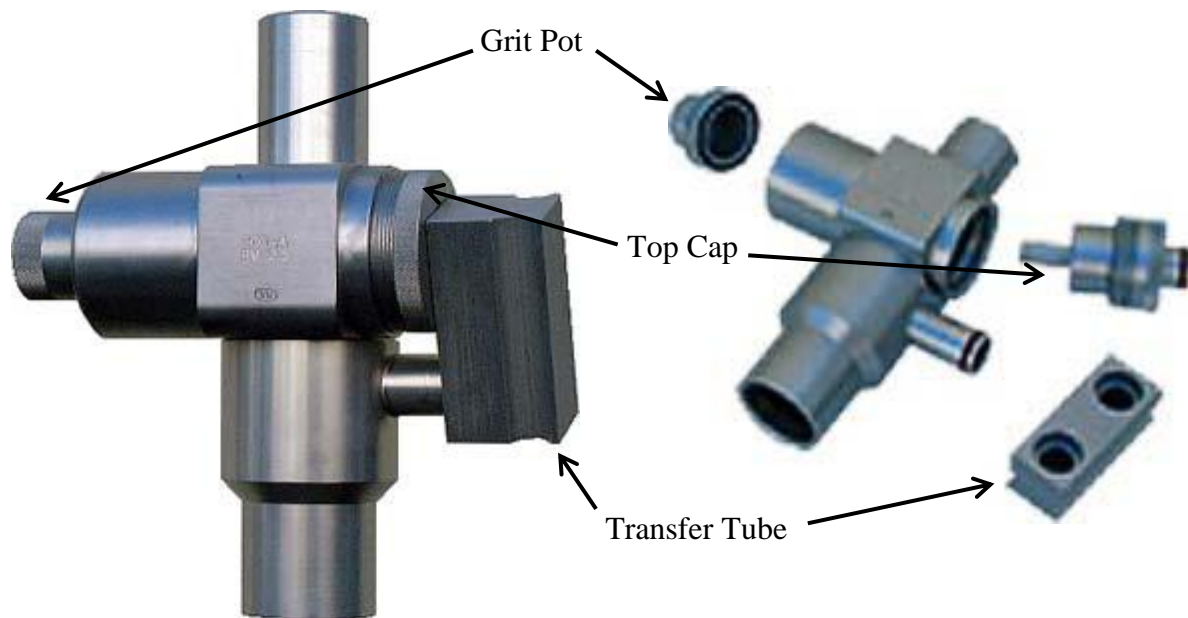

Check Error Log

When at the BAM 1020 the error log can be accessed by pressing the F3 function key (Error Recall). This action will return up to 100 errors logged during the most recent 12 days, sorted by

date. Utilizing the F3 key will not interrupt the sampling cycle and will not provide a copy of the log. To download the error log follow the instruction for digital data download below for the Comet™ program. The error log will also be available by remote access when an external data acquisition system is in place. Errors more than 12 day old require that data be downloaded following the process outlined below.

Digital Data Download

This process applies to manually downloading data to a laptop computer at the monitoring site and not by remote access. Data management and analysis will be covered under a separate SOP.

Follow these steps to download the BAM 1020 data via Comet™:

1. Connect one end of the 9-pin cable to the RS-232 port connector on the Nespelem BAM 1020 (the upper RS232 connector on the back of the unit), and the other to the computer. To connect the Inchelium BAM use the Report RS-232 port by using the connecting cable.
2. Ensure that the BAM 1020 user interface is in the main top-level menu or the OPERATE menu. The serial port is disabled in all other menus.
3. Open the Comet™ program on the laptop and select new to add a station or pick an existing one. If adding a new station, assign a name, pick the monitor type (BAM 1020), and designate COM1 with a Baud rate of 9600. Nespelem is designated as site 02 and Inchelium as site 03.
4. Confirm the station information is correct on the left side of the screen. Press the Retrieve Current button under Data Options,
5. A Retrieve popup window will appear with choices of files to download; setting, data, alarm or all. For the majority of downloads check the all box. Under Data Range click new to download data recorded since the last time. To retrieve all data stored on the BAM 1020 click on the all button. Downloading may take up to 15 minutes if retrieving all data.
6. The Comet™ program will then retrieve the designated data.
7. The three file types, setting, data and alarm, can be viewed immediately or from the file storage location. Use the Open Previous button for a selection of stored files. The Comet™ program saves setting and alarm files as text and data as cvs. These can easily be accessed by utilizing Word or Excel.

Two Month Maintenance and QC

Replace Filter Tape

Follow the instruction under loading filter tape in the Initial Startup and Check section.

Conduct Self-test

Follow the instruction under self-test in the Initial Startup and Check section.

Flow, Temperature and Pressure Calibration

Calibrations are recommended every two months unless all values are within operating limits given above (Table 12). If within the limits no calibration is necessary.

The MULTIPOINT FLOW CALIBRATION screen can be accessed with the Soft Keys via SETUP > TEST > FLOW. When the screen is accessed the BAM 1020 will cease sampling and the nozzle will automatically lower.

Figure 9: MULTIPOINT FLOW CALIBRATION Screen

MULTIPOINT FLOW CALIBRATION				
	TARGET	BAM	STD	
	AT:	23.8	23.8	C
	BP:	760	760	mmHg
<CAL>	FLOW 1:	15.0	15.0	LPM
	FLOW 2:	18.3	18.3	LPM
	FLOW 3:	16.7	16.7	LPM
CAL	NEXT	DEFAULT	EXIT	

On the screen above the target column indicates what the flow should be, the BAM column indicates what is being measured by the BAM. Measurements taken from the standard are entered in the STD column when conducting a calibration.

The ambient temperature (AT) and barometric pressure (BP) must be calibrated prior to the three point flow calibration. The deltaCal reference standard must be equilibrated with the ambient conditions before conducting a calibration. This may take up to 30 minutes if the environment the standard was taken from differs greatly from the ambient.

To conduct the calibrations:

1. Measure the ambient temperature with the reference standard positioned near the BX-596 or BX 592 ambient temperature probe. The hand-held temperature probe should be placed in the radiation shield, or on back side to screen it from direct sun light. Allow the reference standard to stabilize and enter the value from the reference standard into the STD field using the arrow keys. Press the CAL hot key to correct the BAM reading. The BAM and STD temperature values should now be the same.
2. Press the NEXT hot key to move the <CAL> indicator to the BP field, and repeat the same steps for barometric pressure.
3. After the temperature and pressure readings are correct, remove the PM10 inlet and the VSCC™ from the inlet tube and install the reference flow meter onto the inlet. Press the NEXT hot key to move the <CAL> indicator to the first flow point of 15.0 lpm. The pump will turn on automatically. Allow the unit to regulate the flow until the BAM reading stabilizes at the target flow rate. Enter the flow value from your standard into the STD field using the arrow keys. Press the CAL hot key to correct the BAM reading. NOTE: The BAM reading will not change to match the STD until after all three calibration points have been entered.
4. Press the NEXT hot key to move the <CAL> indicator to the second flow point of 18.3 lpm and repeat the process.

5. Press the NEXT hot key to move the <CAL> indicator to the third flow point of 16.7 lpm and repeat the process. Enter the flow value and press <CAL>. When all of the calibrations are complete, the BAM 1020 flow readings should match the traceable flow standard reading at 16.7 lpm, +/- 0.1 lpm.
6. Exit the calibration menu.
7. A regular flow verification should be performed after the calibration is complete and the results entered on the flow verification sheet.

The DEFAULT Soft Key will reset the user calibration from the selected parameter and replace it with a factory setting. If any of the FLOW parameters are selected, the DEFAULT key will reset the calibrations of all three flow points. This feature can be used to start over with a calibration if difficulty is encountered.

Verify the BAM 1020 Settings

The BAM 1020 settings should be verified every two months by comparing them with the expected setting shown in Table 13 below. Instrument specific calibration values are listed on the Calibration Certificate provided with each BAM 1020. A fillable form was created for each site with the constants and location values filled in (Appendix D).

Table 13: Verify BAM 1020 Settings

BAM-1020 PM2.5 Setup and Calibration Values				
Screen	Parameter	Expected/Default	As Found Value	Adjusted Value
SETUP > CLOCK	Clock Time/Date	Local Pacific Standard Time		
SETUP > SAMPLE	RS232	9600, 8N1		
	BAM SAMPLE	Nespelem 50 min Inchelium 42 min		
	STATION #	Nespelem 02 Inchelium 03		
	MET SAMPLE	60 minutes		
	RANGE	1.000 mg		
	OFFSET	-0.015 mg		
	CONC UNITS	µg/m ³		
SETUP > CALIBRATE	COUNT TIME	Nespelem 4 min Inchelium 8 min		
	FLOW RATE	16.7 liter per minute		
	CONC TYPE	Actual		
	FLOW TYPE	Actual		
	Cv	Nespelem 0.990 Inchelium 1.022		
	Qo	Nespelem 0.000 Inchelium -0.099		
	ABS	Nespelem 0.791 Inchelium 0.807		

	µsw	Nespelem 0.293 Inchelium 0.299		
	K Factor	Nespelem 0.939 Inchelium 0.966		
	BKGD	Nespelem -0.0036 Inchelium -0.0023		
	STD TEMP	25 C°		
	HEATER	AUTO		
SETUP > EXTRA1	e1	-0.015 mg		
SETUP > ERRORS	Errors	Enable All		
	AP	150 mmHg		
	FRI	10 lpm		
	FRh	20 lpm		
SETUP > PASSWORD	Password	F1 F2 F3 F4		
SETUP > INTERFACE	Cycle Mode	Data logger specific		
SETUP > HEATER	RH Control	YES		
	RH Setpoint	35%		
	Datalog RH	YES (Chan 4)		
	Delta-T Control	NO		
	Delta-T Setpoint	99		
	Datalog Delta-T	No (Chan 5)		
SETUP > SENSORS	Unused			
SETUP > QUERY	Unused			
SETUP > REPORT	Time Stamp	Nespelem NA Inchelium 01:00 to 24:00		

Six Month Maintenance and QC

Service Pump Muffler

Pump mufflers clog up after several months of use and need replacing or cleaning before the decreased air flow affects the concentration readings. During normal data inspection monitor column 3 (Qtot m3) for changes in air flow values. If the values start to decrease then check the pump muffler and replace. If the air pumps have a 30 inch section of Tygon tubing attached instead of a muffler, check the connection to the pump fitting for security.

Test the Filter Temperature and RH sensors

1. From the Main menu, select TEST and then FILTER-T. This screen is used to calibrate the filter temperature sensor located in the air stream beneath the filter tape. When this screen is entered, the BAM will automatically raise the nozzle and turn the pump on. This action allows the filter temperature sensor to equilibrate with ambient room air without the heating effects of the Smart Heater.

2. Allow the pump to run for at least 5 minutes to allow the sensor to equilibrate. During this same period, allow the reference standard temperature sensor to equilibrate with the room temperature.
3. Press the RESET hot key to clear out any past calibration values.
4. Enter the ambient room temperature from the reference standard into the REFERENCE field using the arrow keys and press the CALIBRATE hot key. The BAM reading should change to match within +/- 1 deg C.
5. The RESET hot key can be used to revert to default calibrations and start over if difficulty is encountered.

To test the filter RH sensor, seldom used or needed.

1. From the Main menu, select TEST and then RH. This screen, which functions exactly like the FILTER-T screen, is used to calibrate the filter RH sensor located in the air stream beneath the filter tape.
2. Allow the pump to run for at least 5 minutes to allow the sensor to equilibrate.
3. Press the RESET hot key to clear out any past calibration values.
4. Enter the ambient room relative humidity from the reference standard into the REFERENCE field and press the CALIBRATE hot key. The BAM reading should change to match within +/- 4% RH.
5. The RESET hot key can be used to revert to default calibrations and start over if difficulty is encountered.

Test Smart Heater

1. From the Main menu, select TEST and then HEATER. This screen is used to force the Smart Heater ON or OFF for testing purposes. The heater takes several minutes to heat up or cool down noticeably.
2. If the heater is on (warm to the touch), force it off to allow it to cool for several minutes. Turn it back on and verify that it warms up.
3. If the heater is cool to the touch when it is initially checked, force the heater on and verify that it warms after several minutes.
4. The heater automatically turns back off upon exit from the screen.

Twelve Month Maintenance and QC

72 hour Background Test

The BX-302 zero filter kit is utilized for this test and follows the procedures given in the instructions. The instructions are included in this document as Appendix E.

Clean or Replace internal debris Filter

An internal debris filter is located in the flow path of the BAM 1020 (see diagram in BAM 1020 Operation Manual, Rev G, page 30). This filter element (Met One PN 580292) should be cleaned or replaced annually.

Check the Membrane Span Foil

The BAM-1020 performs a span check each hour by extending the reference membrane so that it is positioned between the beta source and the scintillation counter. A complete description of this span check process is given in the BAM 1020 Operation Manual (Rev G) on page 28. The value of this measurement is displayed on the NORMAL screen as the "LAST m". The LAST m value

should be very close or equal to the ABS value given on the Calibration certificate. Values in excess of $\pm 5\%$ are flagged as errors (a “D” error for “Deviant Membrane Density”; also known as “Cal error”). If the D error bit is set to ON in the SETUP > ERROR screen, the analog voltage output will also go to full scale.

1. To check the membrane span foil,
2. From the Main menu, choose TEST > CALIBRATE, bringing up the CALIBRATION MODE screen for the reference membrane;
3. Press the START Soft Key to begin the 8-minute test;
4. When complete, record the Calibration mass;
5. Repeat the test two more times (total three tests);
6. Calculate the average mass; and
7. Compare this value with the ABS value in the SETUP >>CALIBRATE screen.

If the calculated average mass is higher than the ABS value for a particular instrument, this may indicate that there is a buildup of material on the membrane; either dirt, or water marks, or some other marking. An average lower than the ABS value could indicate that the high voltage to the Beta Detector tube is low, the count circuit is malfunctioning, or there is a hole or tear in the cellophane material. Inspect the reference membrane for signs of damage; if there is damage; call the Met One Service department.

Perform Beta Detector Count Rate and Dark Count Test

The TEST > COUNT screen allows the check of the function of the beta detector and beta source separate from the rest of the mechanical or flow operations. Each count test will take 4 minutes, and will show the number of beta particles counted as they accumulate. The final count value will stay on the display after the counting is finished, and up to six count tests can be displayed on the screen at once. Count tests are usually performed with a clean section of filter tape between the source and detector, as in normal operation. The test also allows the membrane to be extended between the source and detector as well, if desired.

Press the GO Soft Key to start the 4-minute count test. The counting will immediately begin. After four minutes the counting will stop and wait for the operator to initiate another cycle or EXIT. The resulting COUNT value is the total number of beta particles counted during the four-minute test. This count will increment rapidly during the test. Typical 4-minute count values are between 600,000 and 1,000,000 counts through clean filter tape. The count total will be lower if the span membrane is extended. If the count total is less than 500,000, the beta detector is possibly wearing out.

Clean Inlet Tube

Proper cleaning of the inlet tube requires that the tube be lifted out of the inlet at the top of the BAM-1020. Note: take care to protect the inlet of the BAM-1020 receiver from any debris by placing the red protector over it.

To clean the inlet tube,

1. Remove the PM₁₀ and PM_{2.5} heads and set aside;
2. Loosen the set screws in the BAM-1020 inlet receiver;
3. Loosen the white cap on the roof mounting flange;
4. Loosen the smart heater set screws and lift out the tub;

5. Drop a rope down the tube, and at the bottom end, tie on a clean cloth that can be pulled up through the tube to clean the walls;
6. Repeat until clean;
7. Re-install following the instruction given under Installation Procedures.

Independent Audit

A full audit, conducted annually by an independent reviewer, will provide added assurance that the BAM-1020 is being maintained and operated according to best practices. The auditor may be an individual within an agency not normally responsible for regular maintenance and operation of the instrument. A truly independent audit by an individual from an external agency is preferred if arrangements can be made. A form recommended by Met One (Appendix F) will be used for the full audit documentation.

Replace Lithium Coin Cell Battery

The lithium coin cell battery location on the BAM-1020 3032 circuit board should be replaced annually. This battery provides the power to maintain the BAM-1020 clock and the stored configuration settings and sample data when the instrument is powered down. When changing the battery, the operator needs to pay careful attention to the electrical system as the battery must be changed with the AC power on, otherwise the date/time, data log, and error log will be lost.

Twenty Four Month Maintenance

Rebuild Vacuum Pump

The vacuum pump should be rebuilt every two years. The Medo 925A pump is very easy to rebuild by removing four head bolts, sliding out the old piston and inserting a new one. Pump rebuild kits are available from Met One (PN 680839).

Replace Nozzle O-rings

Replacement of the nozzle O-rings requires special tools found in the BX-308 Service Tool Kit. Follow the complete instruction accompanying the kit.

Replace Pump Tubing

Replace the tubing between the pump and the back of the BAM-1020 at least every two years.

Data Acquisition System

A separate SOP will be written after a DAS system has been chosen for the network.

Data Validation and Quality Assurance

Pertinent to data validation and QA protocols for continuous PM_{2.5} monitoring with the BAM 1020 are the following documents:

1. 40 CFR Part 50 Appendix N (“Interpretation of the National Ambient Air Quality Standards for PM_{2.5}”)
2. 40 CFR Part 50 Appendix L (“Reference Method for the Determination of Fine Particulate Matter as PM_{2.5} in the Atmosphere”)
3. 40 CFR Part 58 Appendix A (“Quality Assurance Requirements for SLAMS, SPMs and PSD Air Monitoring”)
4. EPA Quality Assurance Guidance Document 2.12 (“Monitoring PM_{2.5} in Ambient Air Using Designated Reference or Class I Equivalent Methods”).

These documents offer extensive details about procedures intended to ensure that PM_{2.5} data meets data quality objectives (DQO). All documents are on file in the Air Quality Program office and made available to employees involved with monitoring.

Quality Control Best Practices

The following system comprises the best practices for quality control that will minimize the occurrence of invalid or no data being recorded. Calendar entries should be used to schedule these practices and diligently adhered to. A copy of the BAM 1020 manual, schedule of maintenance, maintenance process instructions and check list sheets are kept current in both monitor enclosures. Central to the best practices concept is the keeping of a site log for each monitor (Appendix G). These logs will document all site visits, actions taken and general notes in as great of detail as possible.

Data Validation

Statistics and settings can be downloaded utilizing the Comet program. Comet automatically downloads a settings tab with current and standard entries. These can then be compared to what was expected as shown in the Setup and Calibration Check Form (Appendix D).

For data to be validated and not invalidated it must fall within the guidance provided in Table 14.

Table 14: Critical and operational data validation criteria for the Met One BAM

Criteria		Frequency	Tolerances	Reference
Critical Criteria: These criteria represent the most important sampling attribute data				
Sampling period	Hourly	Hourly	42 minutes	BAM-1020 Manual, Rev G
	24-hr	Daily	1008 minutes	40 CFR Part 50 AppL, Sec 3.3
Flow statistics (in BAM-1020)	Average Flow Rate	Hourly	±5% of 16.67 lpm 15.87 to 17.54 lpm	40 CFR Part 50 AppL, Sec 7.4; Method 2.12,

CTCR Air Quality Monitoring Network SOP
February 2012

file memory)				Sec 10.2
	Flow Rate Variability	Hourly	Coefficient of variation 2% or less	40 CFR Part 50 AppL, Sec 7.4.3.2
Verification	Single point flow (Reference Std Reading)	Monthly	±5% of Design Flow	40 CFR Part 50 AppL, Sec 7.4; Method 2.12, Sec 10.2
	Single point flow (BAM-1020 Flow Reading)	Monthly	±4% of Reference Std Reading	40 CFR Part 50 AppL, Sec 9.2.5
	Leak Check	Monthly	>1.5 lpm	Agency specific
Operational Criteria: These criteria represent tolerances when corrective action may be needed to reestablish optimal sampling attributes				
Verification /Calibration	Leak Check	Monthly	>1.0 lpm	
	Reference membrane	Hourly	±5% of ABS ("D" error)	BAM-1020 Manual, Rev G
	BX-596 Temp Verification	2 Months	±2°C	40 CFR Part 50 AppL, Sec 9.3; Method 2.12, Sec 6.4
	BX-596 Temp Calibration	2 Months	±0.2°C	BAM-1020 Manual, Rev G
	BX-596 Barometric Pressure Verification	2 Months	±10 mm Hg	40 CFR Part 50 AppL, Sec 9.3; Method 2.12, Sec 6.5
	BX-596 Barometric Pressure Calibration	2 Months	±1 mm Hg	BAM-1020 Manual, Rev G
	3-Point Flow Calibration	2 Months or on Failed Flow Check	±0.1 lpm	BAM-1020 Manual, Rev G
	Filter RH Calibration	6 Months	±4% RH	BAM-1020 Manual, Rev G
	Filter Temp Calibration	6 Months	±1°C	BAM-1020 Manual, Rev G
Cleaning	PM10 Inlet SCC™ and VSCC™	Monthly	Cleaned	BAM-1020 Manual, Rev G; Method 2.12, Sec 9.3
	Nozzle, vane, pinch roller, capstan	Monthly	Cleaned	BAM-1020 Manual, Rev G
Other Mfg Recommended Maintenance	Clean pump muffler; test Smart heater	6 Months	Verified	BAM-1020 Manual, Rev G
	Zero filter test; Clean internal filter; Beta detector test; check span foil; clean inlet tube	12 Months	Verified	BAM-1020 Manual, Rev G

Data Validation Steps

Table 15 list sequential steps, components and procedures for validation of monitoring data based on criteria mentioned in several sections above and EPA Quality Assurance Guidance Document 2.12.

Table 15: Data Validation Steps for BAM 1020

Validation Step	Component	Procedure
Verify Data Source	Direct Data Download	Download csv Data File
		Download Settings File
		Download Alarm File
Review BAM 1020 Attribute Data	Full scale concentration, Analog data	Sort records for full scale data (0.985 mg); look for errors causing FS output but digital CONC data are valid (e.g., errors P, R, N, E), if found, retrieve digital data.
	Full scale concentration, Digital data	Usually maintenance (M) or power fail (L) errors: invalidate
	Qtot	A good validation indicator. If Qtot varies, suggests a problem with temperature or pressure probe, or pump. Recommend rigid tolerance for Qtot
	Error flags	Review specific errors and invalidate accordingly
Review BAM-1020 Flow Statistics	Elapsed time	Nespelem 50 minutes Inchelium 42 minutes
	Average flow	±4% of 16.67 lpm
	Coefficient of variation	< 2%
	Sample volume	Recommend rigid tolerance for Qtot (0.700 ±0.003 m3)
	Temperature and Pressure Stats	Average, Max, Min for reasonableness
Review Field QC (Operator log sheets)	Flow checks	±4% of 16.67 lpm
	Leak checks	> 1.5 lpm, invalidate back to last passing leak check
	Calibration	At least annually, or on failed verification
Maintenance procedures	Inlet cleaning	Verify inlets cleaned (30 days for VSCC™)
	Periodic zero test	Verify and evaluate

Periodic component tests	Test: Filter T and RH, Smart Heater, Beta Count Rate, Analog DAC	Verify (Operator log sheets)
--------------------------	--	------------------------------

Diagnostics and Troubleshooting

The Met One BAM 1020 Operation Manual provides troubleshooting tables (Rev G, pages 53-56) containing information on some of the more common BAM 1020 problems which may be encountered, and some steps to identify and remedy the problems. If problems arise that are not covered in the manual the manufactures technical helpline or email inquiry may be used.

Met One Technical Helpline – (541) 471-7111; Fax (541) 471-7116

Met One Technical email - service@metone.com

Address: Technical Services Department
Met One Instruments Inc.
1600 NW Washington Blvd.
Grants Pass, OR 97526

Additionally Met One offers in depth operation and maintenance training at their Grant Pass Oregon facility. Call or email the technical division at the contact information above to arrange for this training.

Consumables and Spare Parts

Items shown in Table 13 are suggested to be kept available to insure the smooth operation of the BAM 1020.

Table 16: Suggested Consumable and Spare Parts to Keep Available

Consumable or Part	Met One Part Number	Usage
Filter tape roll	460130	60 days/roll
Cotton-Tipped Applicators	995217	Nozzle, vane, inlet cleaning
Isopropyl alcohol		Nozzle, vane, inlet cleaning
Pump rebuild kit	Medo (680839)	Recommended rebuild every two years
In-line filter element	580292	Replace as needed
O-rings, Nozzle	720066	Replace as needed
O-rings, Inlet receiver (2 required)	720069	Replace as needed
Fuse, 3.15A, 250V, 5x20mm (2 Required)	590811	Replace as needed
O-Rings, VSCC™, set of 6	720097	Replace as needed
O-Rings, PM10 Head, set of 3	8965	Replace as needed
Low lint wet wipes		Nozzle, vane, inlet cleaning

Hand cleaner		Tape loading, inlet cleaning
--------------	--	------------------------------

References

EPA Requirements for Quality Assurance Project Plans, EPA QA/R-5, Office of Environmental Information, Washington DC, EPA/240/B-01/003, March 2001

Guidance for Quality Assurance Project Plans, EPA QA/G5, Office of Environmental Information, Washington DC, EPA/240/R-02/009, December 2002

Guidance on Systematic Planning Using the Data Quality Objectives Process, EPA QA/G-4, Office of Environmental Information Washington DC, EPA/240/B-06/0001, February 2006

Guidance for Preparing Standard Operating Procedures (SOPs), EPA QA/G-6, Office of Environmental Information Washington DC, EPA/6000/B-07/001, April 2007

Met One Instruments, Inc., (2008) BAM 1020 particulate monitor operation manual. Prepared by Met One Instruments, Inc., Grants Pass, OR, BAM-1020-9800 Rev G.

Standard Operating Procedure for the Continuous Measurement of Particulate Matter, Met One BAM-1020 PM2.5 Federal Equivalent Method EQPM-0308-170, STI-905505.05-3645-SOP, David L. Vaughn, Sonoma Technology, Inc.

Technical Guidance for the Development of Tribal Air Monitoring Programs, EPA-456/B-07-002, August 2007

U.S. Environmental Protection Agency (1998) Quality assurance guidance document 2.12: Monitoring PM_{2.5} in ambient air using designated reference or Class I equivalent methods. Prepared by the Human Exposure and Atmospheric Sciences Division, National Exposure Research Laboratory, Research Triangle Park, NC, November.

Quality Manual for Environmental Programs, EPA, CIO 2105-P-01-0, May 5, 2005

Appendices